

D05 High Flow Series Circuit Manifold

(See Page 1.99.01 for Relief Cartridges)

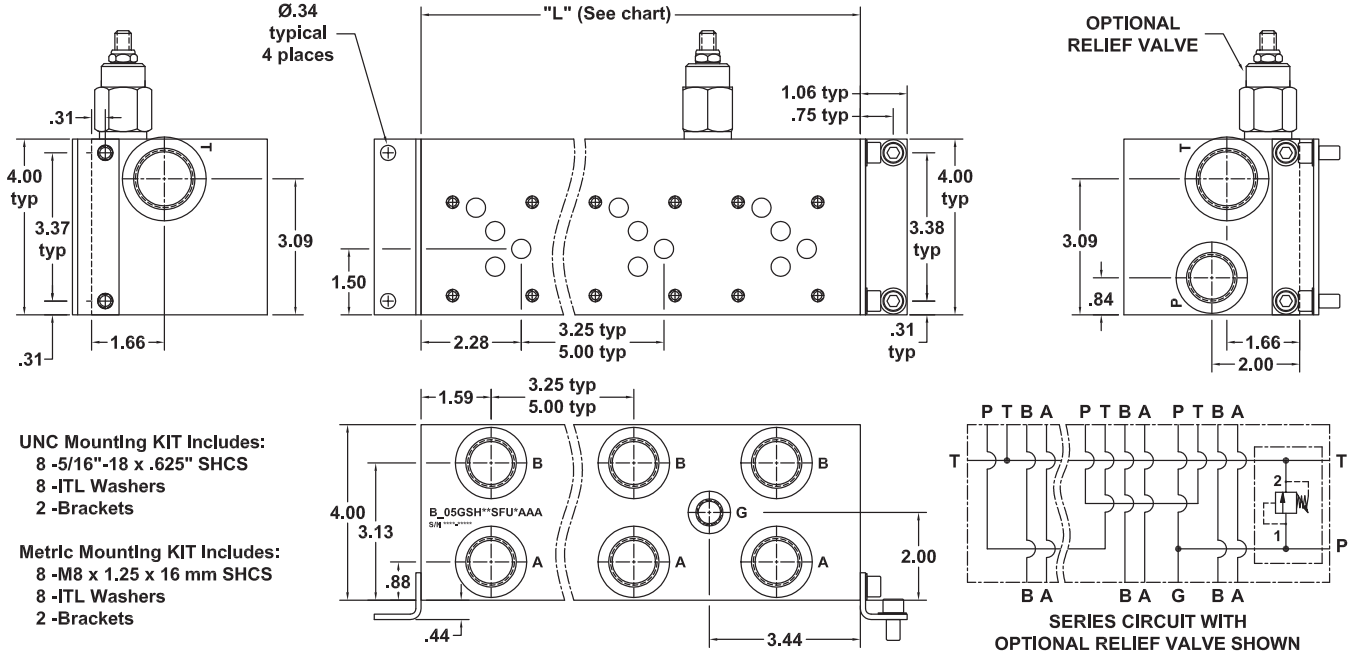

UNC Mounting KIT Includes:
8 -5/16"-18 x .625" SHCS
8 -ITL Washers
2 -Brackets

Metric Mounting KIT Includes:
8 -M8 x 1.25 x 16 mm SHCS
8 -ITL Washers
2 -Brackets

No. of Stations	2	3	4	5	6
Dim. "L", 3.25" spacing	6.75	10.00	13.25	16.50	19.75
est. weight in lb.- alum	10	15	20	25	29
est. weight in lb.- iron	27	40	52	65	78
Dim. "L", 5.00" spacing	8.50	13.50	18.50	23.50	28.50
est. weight in lb.- alum	13	20	27	35	42
est. weight in lb.- iron	34	53	73	92	112

SHADED AREA AVAILABLE ON SPECIAL ORDER ONLY

- NOTES:** 1) FOR PILOT PORT OPTIONS SEE D05 BAR MANIFOLD ADAPTER SHEETS ON PAGES 1.03.11 & 1.03.12
2) P-T MAIN SYSTEM RELIEF AVAILABLE AS A STANDARD OPTION

PART NUMBER SYSTEM

Aluminum D05 with 3.25" spacing and SAE porting example: **BA05GSH**SFUAAAA**

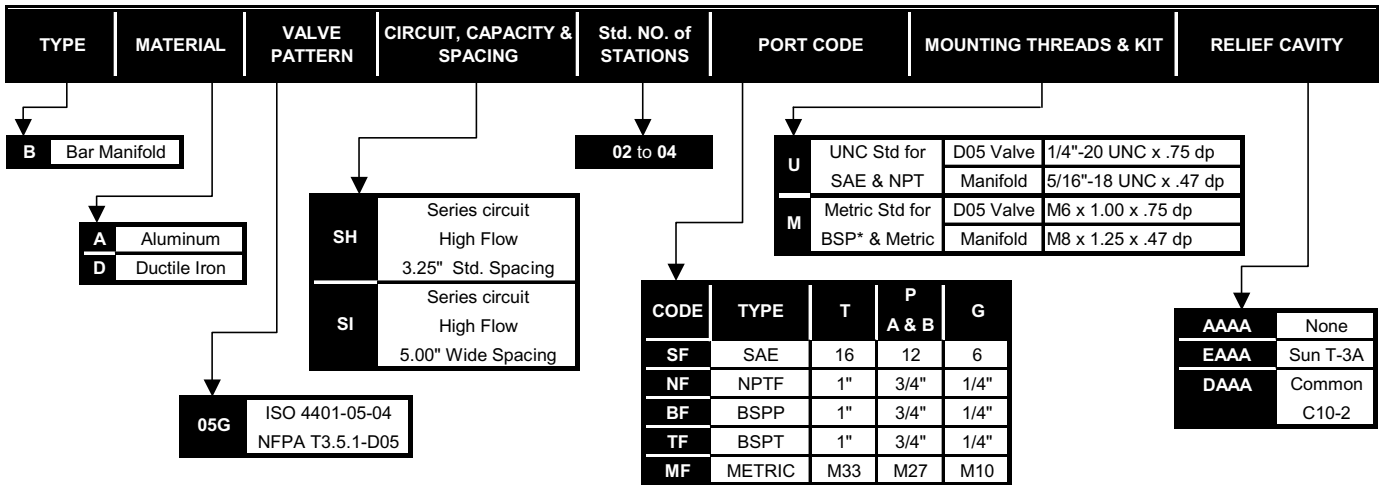

WE RESERVE THE RIGHT TO DISCONTINUE MODELS, OR CHANGE SPECIFICATIONS WITHOUT NOTICE OR INCURRING OBLIGATION

Lynch Products Can Be Modified to Suit Your Application

Phone: 1 (888) 626-4365 or +1 (905) 363-2400 Fax: 1 (800) 263-5807 www.lynch.ca sales@lynch.ca