

D05 Very High Flow Parallel Circuit Manifold

(See Page 1.99.01 for Relief Cartridges)

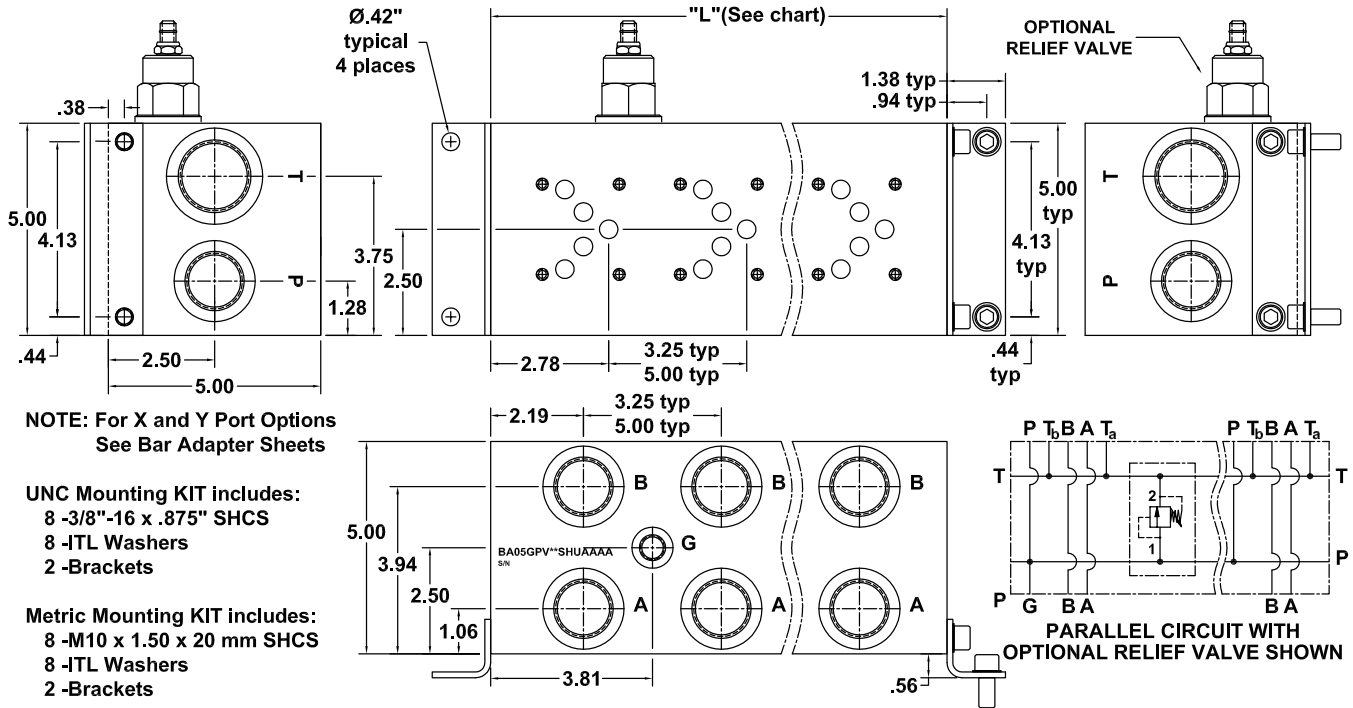

No. of Stations	1	1*	2	3	4	5	6	7	8	9	10	11
Dim. "L", 3.25" spacing	4.25	5.50	7.50	10.75	14.00	17.25	20.50	23.75	27.00	30.25	33.50	36.75
est. weight in lb.- alum	11	14	19	26	34	42	49	57	65	73	80	88
est. weight in lb.- iron	28	36	49	70	91	111	132	153	174	195	216	224
Dim. "L", 5.00" spacing	-	-	9.25	14.25	19.25	24.25	29.25	34.25	39.25	-	-	-
est. weight in lb.- alum	-	-	23	35	46	58	70	82	94	-	-	-
est. weight in lb.- iron	-	-	60	92	124	156	188	220	252	-	-	-

* DIMENSIONS FOR 1 STATION WITH RELIEF CAVITY & GAUGE PORT
NO GAUGE PORT SUPPLIED WITH SINGLE STATION MANIFOLD
SHADED AREA AVAILABLE ON SPECIAL ORDER ONLY

PART NUMBER SYSTEM

Aluminum D05 with 3.25" Spacing & SAE Porting example: BA05GPV**SHUAAAA

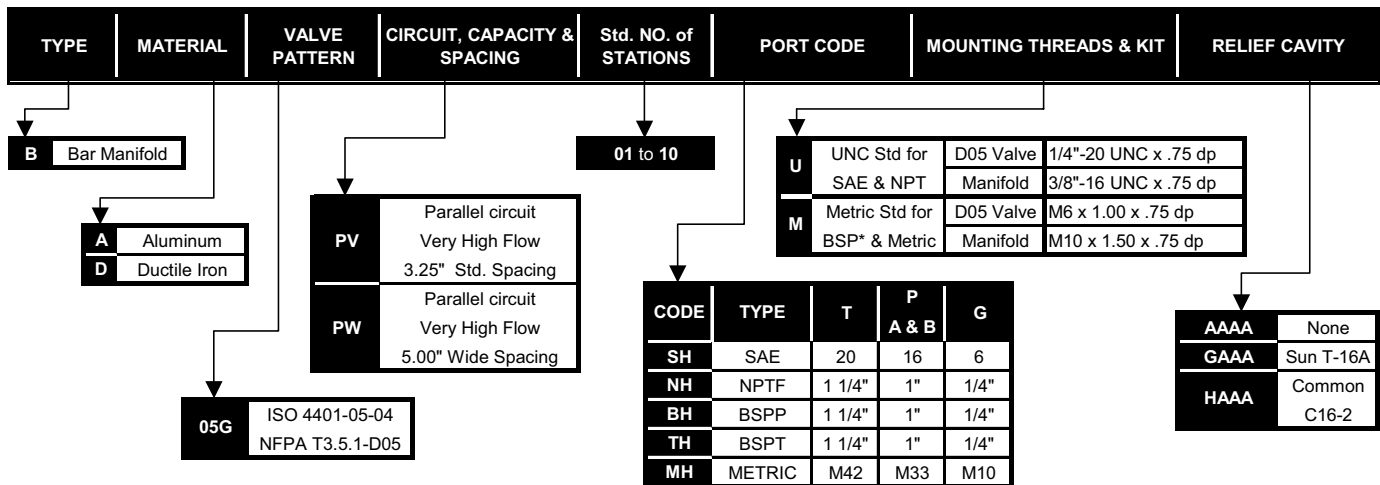

WE RESERVE THE RIGHT TO DISCONTINUE MODELS, OR CHANGE SPECIFICATIONS WITHOUT NOTICE OR INCURRING OBLIGATION

Lynch Products Can Be Modified to Suit Your Application